



CLOUD CONNECT ADVANCED

ADVANCED COMMUNICATIONS AND COMPACT SIZE

- Tigo's Cloud Connect Advanced (CCA) is one of the smallest communication data loggers on the market.
- Connects smart modules to the Cloud and the Tigo Smart Monitoring software.
- Enables module-level disconnect.
- Allows on-site system configuration via Tigo's SMART mobile app.
- Comes with RS-485 port software and hardware for robust third party compatibility: read and report data from Modbus equipped inverters, charge controllers, weather stations, smart combiner boxes, and revenue grade meters. See list of supported devices: <https://support.tigoenergy.com/hc/en-us>
- Equipped with Tigo's Smart OS to support custom applications through extensive APIs.

INTERNET CONNECTION

Internet connection via Ethernet, Wi-Fi, or optional cellular* connectivity built in.

MOBILE APP SET UP AND ACCESS

Configure the CCA with the Tigo SMART App.
The Wi-Fi capabilities of the CCA provide direct access and straightforward commissioning.

COST EFFECTIVE

Advanced technologies make the CCA cost-effective for large scale deployment.

APPLICATION PLATFORM

Tigo's SMART OS allows third parties to develop and deploy apps to the CCA through Apple's App Store and Google Play.



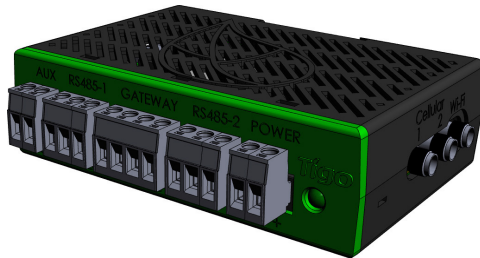
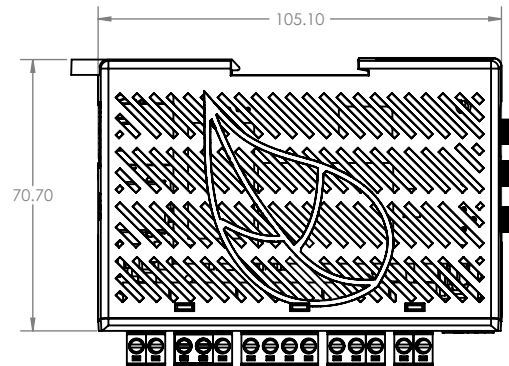
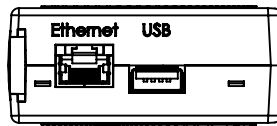
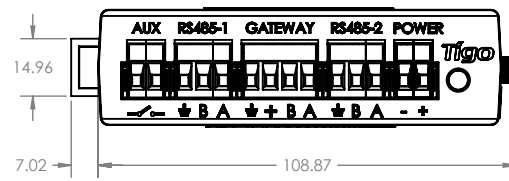
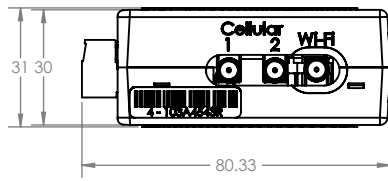

Electrical

CCA Consumption

Input Voltage: 6VDC - 25VDC (12VDC minimum when using Gateways. 24VDC for 2+ Gateways)

Input Current: 1.8 A Maximum (internally protected and self resetting)

Power Consumption: Typical (with 1 GW): Less than 3W. Max. 16W

0.5W for each added Gateway

5W Max for cellular option

Available ports

RS485-1 AND RS485-2 for Inverter/AC Meter/MODBUS/etc.

USB 2.0, output 5W, 1A

Power supply

Input voltage: 100-240VAC, 50-60 Hz

Form factor options: DIN Rail (part number:344-00000-00) OR Socket (Part number:344-00000-10)

Capacity

Each CCA supports up to 360 PV modules. For more options visit: <https://support.tigoenergy.com/hc/en-us/articles/201998767>

Internet Connectivity Options

Ethernet Interface: 10/100-BaseT with Straight-Through or Crossover cable detection.

Wireless Interface: Wi-Fi, IEEE 802.11 b/g/n 2.4 GHz

One Wi-Fi Antenna: 2.4–2.5 GHz, 50Ω (RP-SMA plug, Male)

Cellular Modem: Verizon LTE (USA ONLY. Optional, sold separately)

Two LTE Antennas: 2.4–2.5 GHz, 50Ω (SMA plug, Male)

Mechanicals

DIN Rail, mountable enclosure

Dimensions (with housing, no antennas, WxHxD): 31mm X 115.51mm x 71.54mm (1.22" X 4.55" X 2.82")

Weight (CCA + Housing): 126g / 0.278 lb.

Weight (CCA + Housing + Modem): 0.158 kg / 0.348 lb.

Operating Temperature Range -20°C to +70°C (-4° to 158°F)

Cooling: Natural Convection – No Fans

User Interface

Mobile App: iOS and Android (connected via Wi-Fi directly to CCA) <https://support.tigoenergy.com/hc/en-us/articles/204899957>

Multi-function LED indicator: (Red/Green/Orange). View Guide here: <https://support.tigoenergy.com/hc/en-us/articles/204899957>

For supported protocols and devices, see: <https://support.tigoenergy.com/hc/en-us/sections/200408647>



For ordering information

Contact: sales@tigoenergy.com

Or call: 1.408.402.0802

For more information about Tigo products:

Go to www.tigoenergy.com/products

