

DH200F

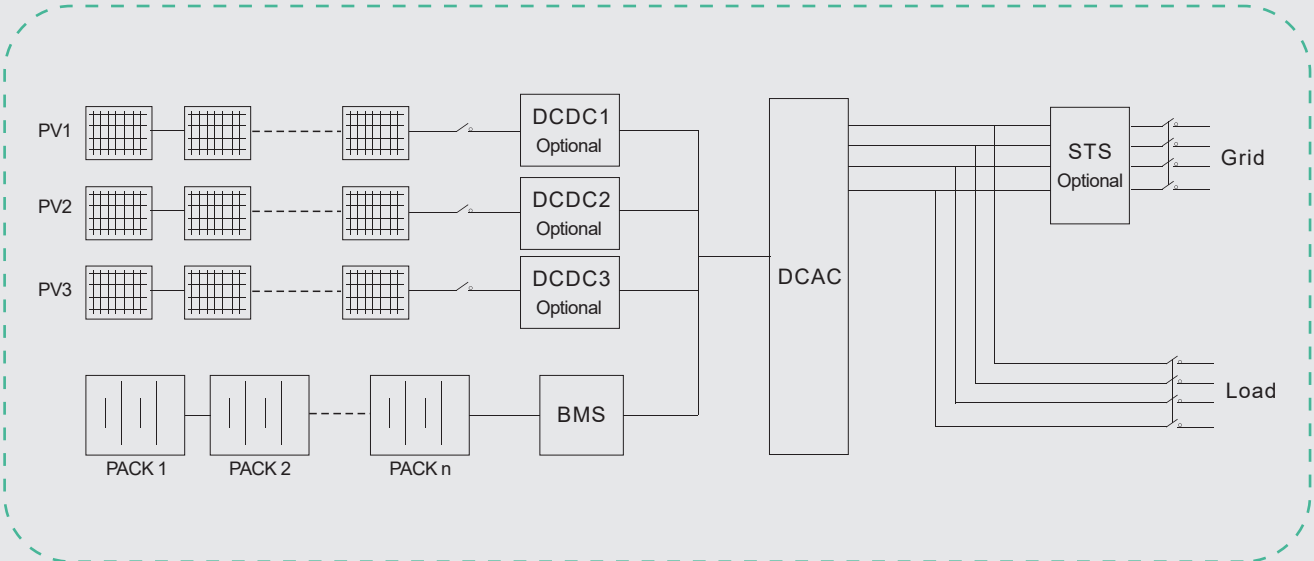

The All-in-one fully integrated design of a single cabinet meets industrial and commercial energy storage application scenarios.

- Full-scenario
- Highly Efficient and Flexible
- Ultimate Security



Technical Specifications

Battery Technical Specifications	
Battery Type	LFP (LiFePO4)
Cell Capacity	280Ah
Module Configuration	1P16S
PACK quantity	One cluster/15 PACK
Battery Voltage Range	672-864V
System Capacity	215kWh
PV Parameters	
Input Voltage	200-670V
Number of MPPT Trackers	0~3
MPPT Power	50 kW per channel*3
AC Output(On Grid)	
Rated Output Power	100kW
Rated Output Voltage	400Vac
Voltage Range	320 Vac ~460 Vac
Wiring Method	3P4L+PE
Rated output frequency	50Hz/60Hz (Settable)
Grid frequency Range	45-55Hz /55-65Hz (Settable)
THDi	≤3% (Rating power)
AC Output(Off Grid)	
Rated Output Power	100kW
Rated Output Voltage	400Vac
Voltage Range	320 Vac ~460 Vac
Wiring Method	3P4L+PE
Rated output frequency	50Hz/60Hz(Settable)
Grid frequency Range	45-55Hz /55-65Hz(Settable)
Switch Time	≤20ms
System parameters	
Dimensions (W*D*H)	1850*1200*2250mm
Weight	about 2800kg
Operating Temperature Range	-20~50°C(Reduction above 45 °C)
Operating Humidity Range	0~95%(No condensation)
IP Protection	IP55
Anti-corrosion	C3
Noise	≤75dB
Elevation	3000m(>2000m derating)
Cooling Method	Air cooling
Display	Touchscreen
Fire Fighting	Optional: Aerosol/Heptafluoropropane (FM-200)/Perfluorohexandone (Novec1230)
Communication Port	Ethernet/4G
Cycle Life	6000 cycles/80% EOL (25°C, 100% DOD, 0.5P)
Standards	IEC62619、IEC63056、IEC60730、EN62477、EN61000-6-2/4、GB/T 36276